

NO	PARTS NAME	MATERIAL	QUTY	COLOR
1-A	U-PANEL	6OZ uncoated	1	WHITE
1-B	SIDE PANELS	6OZ uncoated	2	WHITE
2	TOP PANEL	2.5OZ coated cone top availability size 48"X51"	1	WHITE
3	BOTTOM PANEL			
4	FILLING SPOUT	2.5OZ coated	1	WHITE
5	DISCHARGE SPOUT	2.5OZ coated	1	WHITE
6	LIFTING STRAPS	2.75" WIDTH	4	BLACK
7	TIE TAPES	1/2" WIDTH	2	WHITE
8	DISCHARGE ROPE	0.24" DIA	1	WHITE
9	DOCUMENT POUCH	12"x13"Hx7mil pe	1	
10	REINFORCED BELT	2.75" WIDTH	4	BLACK
11	REINFORCED FABRIC	6OZ uncoated 5.9"X15.7"H	8	WHITE
12	SPOUT COVER	6OZ uncoated	1	WHITE
13	BAFFLES	5OZ coated	4	WHITE
U型身与堵结合夹无防布				

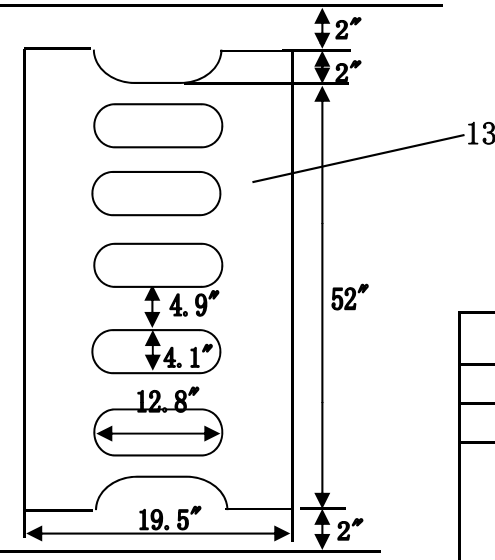

MODEL	DATE
Bulk Bag 40"X43"X58"-BAFFLE	2010.5-20

